

Measurements and angles

Cotes et angles

Misure ed angoli

Maten en hoeken



Maße & Winkel



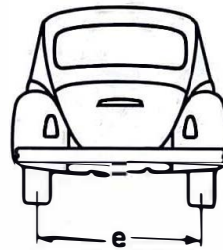
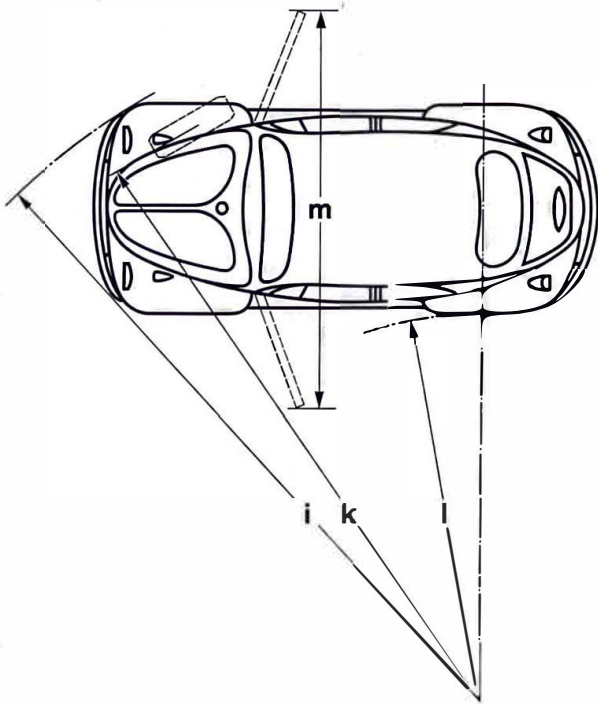
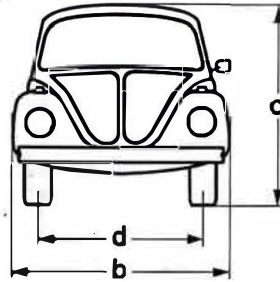
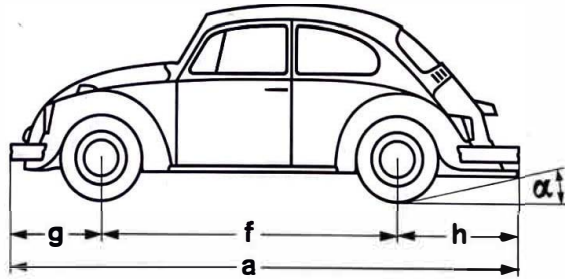





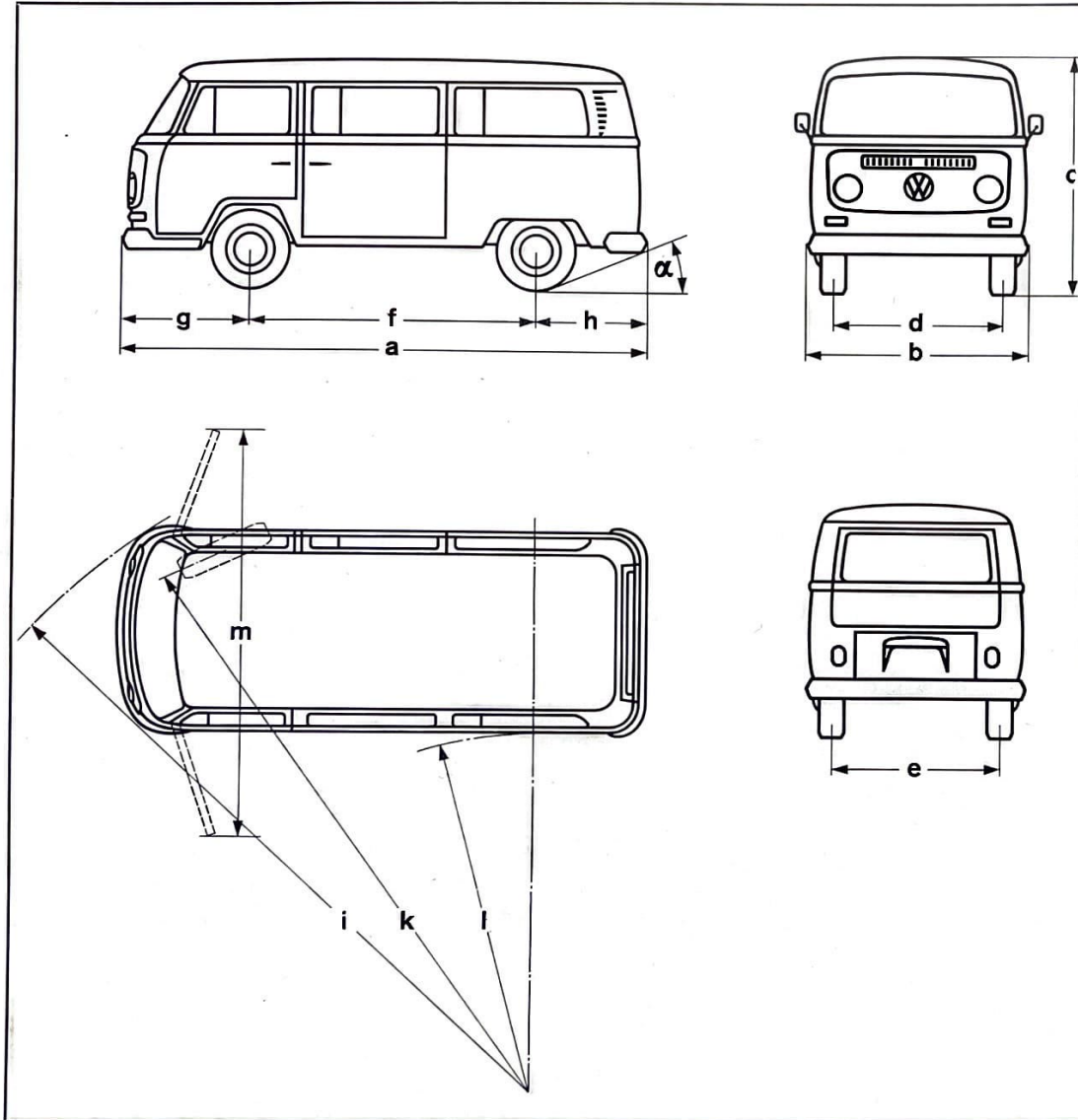

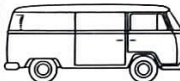
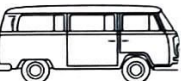
	mm (in.)	mm (in.)
a	4030 (158.7)	4140 (163 )
b	1550 ( 61 )	1634 ( 64.3)
c	1500 ( 59.1)	1320 ( 52 )
d	1316 ( 51.8)	1316 ( 51.8)
e	1350 ( 53.1)	1350 ( 53.1)
f	2400 ( 94.5)	2400 ( 94.5)
g	720 ( 28.3)	810 ( 31.9)
h	910 ( 35.8)	930 ( 36.6)
m	3200 (126 )	3400 (133.9)
	m (ft.)	m (ft.)
i	5,5 ( 18 )	5,65 ( 18.5)
k	5,25 ( 17.2)	5,25 ( 17.2)
l	3,1 ( 10,2)	3,1 ( 10.2)

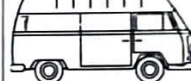

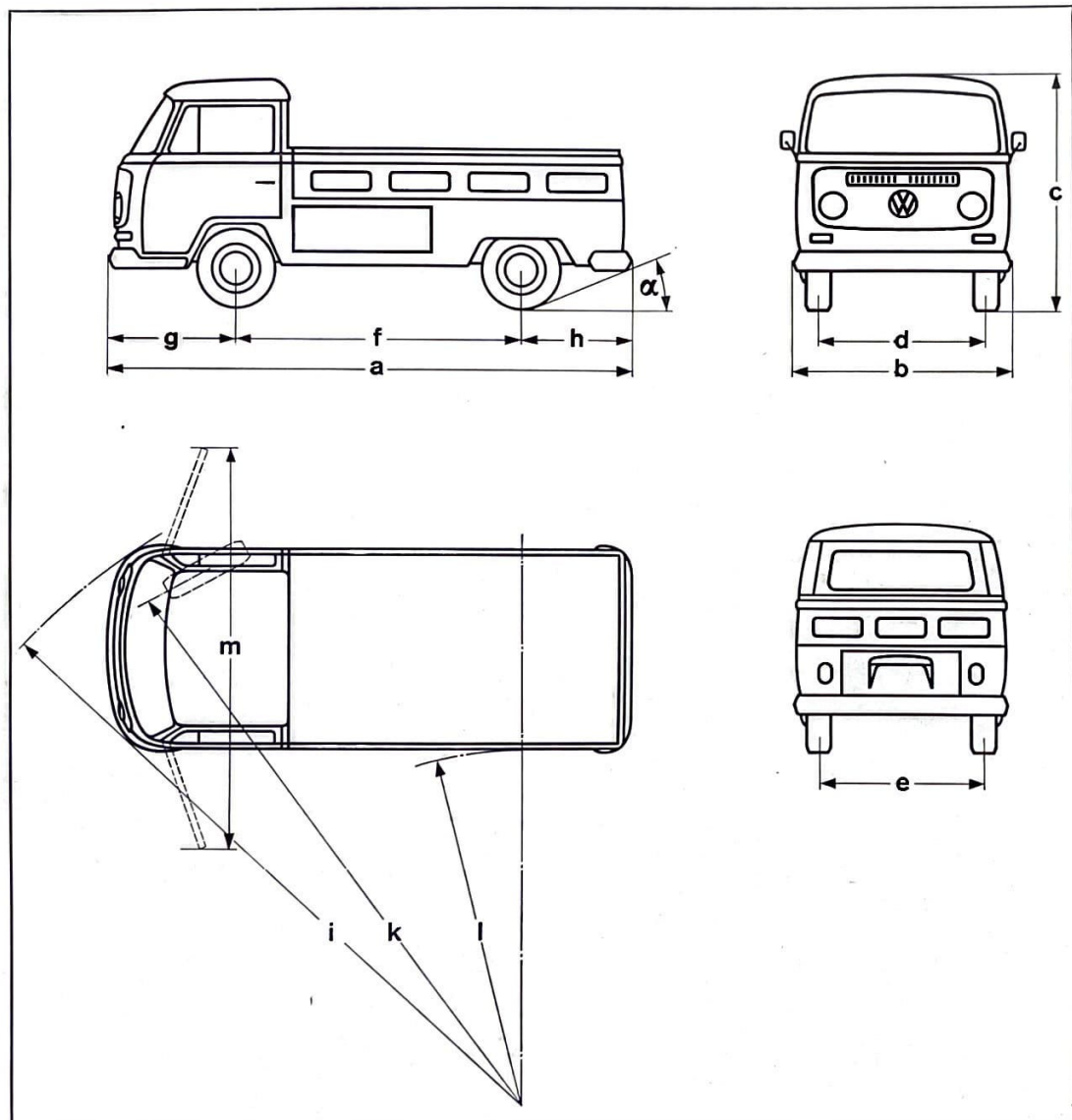

	 mm (in.)	 mm (in.)	 mm (in.)	 mm (in.)
a	4420 (174 )	4445 (175 )	4420 (174 )	
b	1765 ( 69.5)	1815 ( 71.5)	1765 ( 69.5)	
c	●	1940 ( 76.4)	●	
d	1385 ( 54.5)	1385 ( 54.5)	1385 ( 54.5)	
e	1426 ( 56.1)	1426 ( 56.1)	1426 ( 56.1)	
f	2400 ( 94.5)	2400 ( 94.5)	2400 ( 94.5)	
g	1075 ( 42.3)	1077 ( 42.4)	1075 ( 42.3)	
h	945 ( 37.2)	968 ( 38.1)	945 ( 37.2)	
m	3600 (141.7)	3600 (141.7)	3600 (141.7)	
	m (ft.)	m (ft.)	m (ft.)	
i	6,15 ( 20.2)	6,15 ( 20.2)	6,15 ( 20.2)	
k	5,65 ( 18.5)	5,65 ( 18.5)	5,65 ( 18.5)	
l	4,10 ( 13.5)	4,15 ( 13.6)	4,10 ( 13.5)	

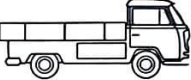

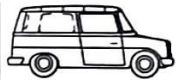

				
	mm (in.)	mm (in.)	mm (in.)	mm (in.)
a	4420 (174 )	4470 (176 )	4420 (174 )	3970 (156.3)
b	1765 ( 69.5)	1980 ( 78 )	1765 ( 69.5)	1670 ( 65.7)
c	1955 ( 75 )* 2245 ( 88.4)**	1955 ( 77 )	1950 ( 76.8)* 2220 ( 88.4)**	1730 ( 68.1)
d	1385 ( 54.5)	1385 ( 54.5)	1385 ( 54.5)	1310 ( 51.6)
e	1426 ( 56.1)	1426 ( 56.1)	1426 ( 56.1)	1350 ( 53.1)
f	2400 ( 94.5)	2400 ( 94.5)	2400 ( 94.5)	2400 ( 94.5)
g	1075 ( 42.3)	1075 ( 42.3)	1075 ( 42.3)	670 ( 26.4)
h	945 ( 37.2)	995 ( 39.2)	945 ( 37.2)	900 ( 35.4)
m	3600 (141.7)	3600 (141.7)	3600 (141.7)	1800 ( 70.9)
	m (ft.)	m (ft.)	m (ft.)	m (ft.)
i	6,15 ( 20.2)	6,15 ( 20.2)	6,15 ( 20.2)	5,6 ( 18.4)
k	5,65 ( 18.5)	5,65 ( 18.5)	5,65 ( 18.5)	5,25 ( 17.2)
l	4,10 ( 13.5)	4,00 ( 13.1)	4,10 ( 13.5)	3,1 ( 10.2)

\* ohne Plane und Spriegel



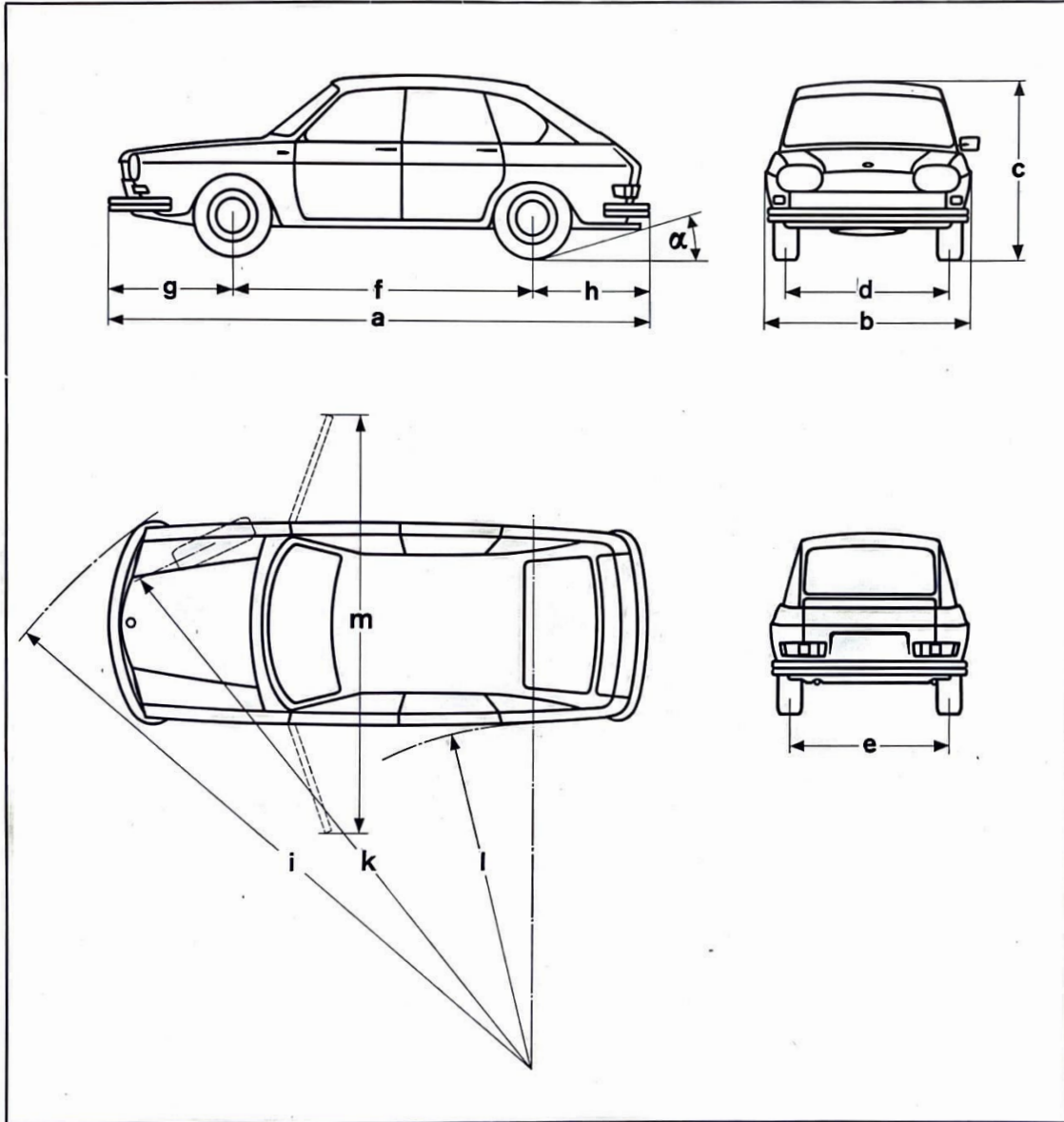

\*\* mit Plane und Spriegel

\* without tilt and bows • sans bâche ni arceaux • senza centine e telone • zonder huif en spanten  
 \*\* with tilt and bows • avec bâche et arceaux • con centine e telone • met huif en spanten

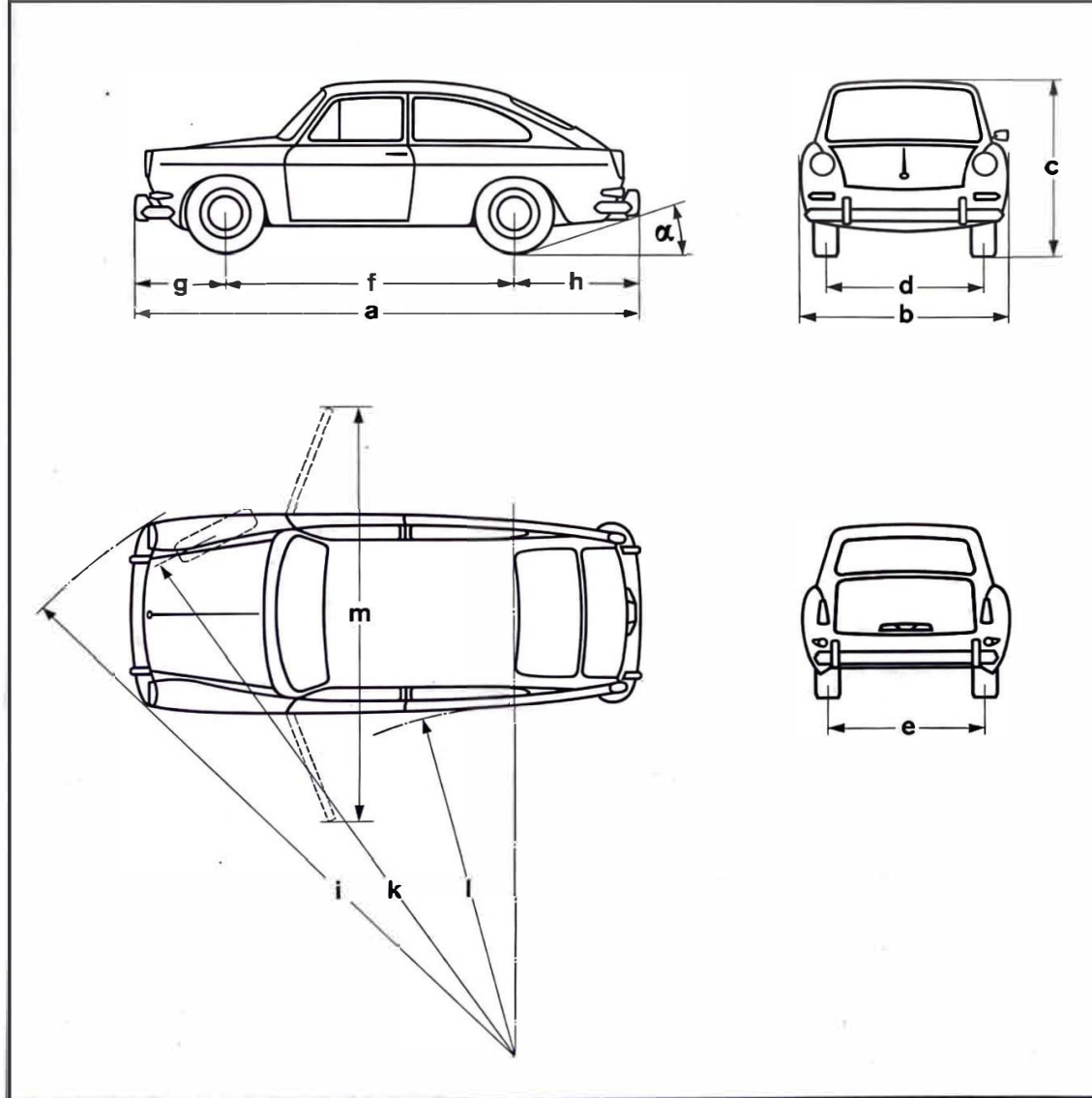

		
	mm (in.)	mm (in.)
a	4553 (159.8)	4553 (159.8)
b	1376 ( 54.2)	1376 ( 54.2)
c	1485 ( 58.4)	1485 ( 58.4)
d	1650 ( 65.0)	1650 ( 65.0)
e	1342 ( 52.8)	1342 ( 52.8)
f	2500 ( 98.4)	2500 ( 98.4)
g	1069 ( 42.0)	1069 ( 42.0)
h	984 ( 38.7)	984 ( 38.7)
m	3000 (118 )	3300 (130 )
	m (ft.)	m (ft.)
i	5,7 ( 18.7)	5,7 ( 18.7)
k	5,2 ( 17 )	5,2 ( 17 )
l	3,6 ( 10.7)	3,6 ( 10.7)



	 mm (in.)	 mm (in.)	 mm (in.)	 mm (in.)
a	4225 (166.3)	4225 (166.3)	4225 (166.3)	4280 (168.5)
b	1640 ( 64.6)	1640 ( 64.6)	1640 ( 64.6)	1620 ( 63.8)
c	1470 ( 57.9)	1470 ( 57.9)	1470 ( 57.9)	1330 ( 52.4)
d	1310 ( 51.6)	1310 ( 51.6)	1310 ( 51.6)	1310 ( 51.6)
e	1346 ( 53 )	1346 ( 53 )	1346 ( 53 )	1346 ( 53 )
f	2400 ( 94.5)	2400 ( 94.5)	2400 ( 94.5)	2400 ( 94.5)
g	785 ( 30.9)	785 ( 30.9)	785 ( 30.9)	848 ( 33.4)
h	1040 ( 40.9)	1040 ( 40.9)	1040 ( 40.9)	1032 ( 40.6)
m	3500 (137.8)	3500 (137.8)	3500 (137.8)	3500 (137.8)
	m (ft.)	m (ft.)	m (ft.)	m (ft.)
i	5,55 ( 18.2)	5,55 ( 18.2)	5,55 ( 18.2)	5,30 ( 17.4)
k	5,15 ( 16.9)	5,15 ( 16.9)	5,15 ( 16.9)	5,15 ( 16.9)
l	3,50 ( 11.5)	3,50 ( 11.5)	3,50 ( 11.5)	3,50 ( 11.5)



**Maße und Winkel  
für den Bau von Garagen**

**Measurements  
and angles for erection of garages**

**Cotes et angles  
pour la construction de garages**

**Misure ed angoli  
per la costruzione di autorimesse**

**Maten en hoeken voor garages**

„Maße und Winkel“ — eine Antwort auf die Frage, wie ein Volkswagen mühelos unter Dach und Fach zu bekommen ist. Legen Sie Ihren Plänen die maßstäblichen Zeichnungen 1 : 50, 1 : 100 und 1 : 200 zugrunde. Es wird Ihre Arbeit erleichtern.

“Measurements and Angles” — an answer to the question as to how a Volkswagen can easily be housed. Base your plans on the 1 : 50, 1 : 100 and 1 : 200 scaled drawings. It will simplify your task.

« Cotes et angles » — Une réponse à la question : Comment peut-on mettre facilement une Volkswagen à l'abri ? Prenez les dessins au 50ème, 100ème et 200ème comme base pour vos plans. Votre travail en sera facilité.

“Misure ed angoli” — una risposta alla domanda come si possa mettere al “sicuro” una Volkswagen. Tenete presente come base per i vostri progetti i disegni in scala 1 : 50, 1 : 100 e 1 : 200. Il vostro lavoro ne risulterà facilitato.

„Maten en hoeken“ — geeft antwoord op de vraag, hoe u een Volkswagen zonder moeite onder dak kunt krijgen. Als u bij uw ontwerpen van bijgevoegde tekeningen uitgaat — schaal 1 : 50, 1 : 100 en 1 : 200 — zal dat uw taak aanzienlijk vereenvoudigen.

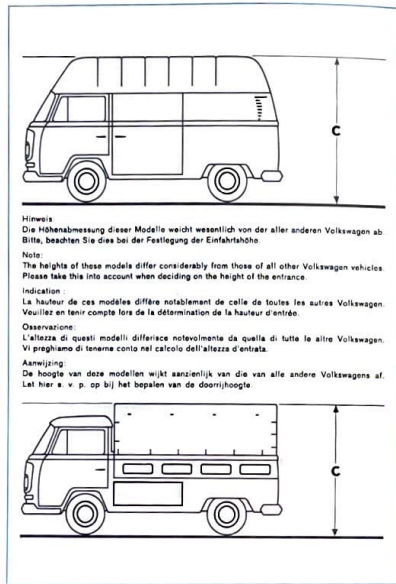
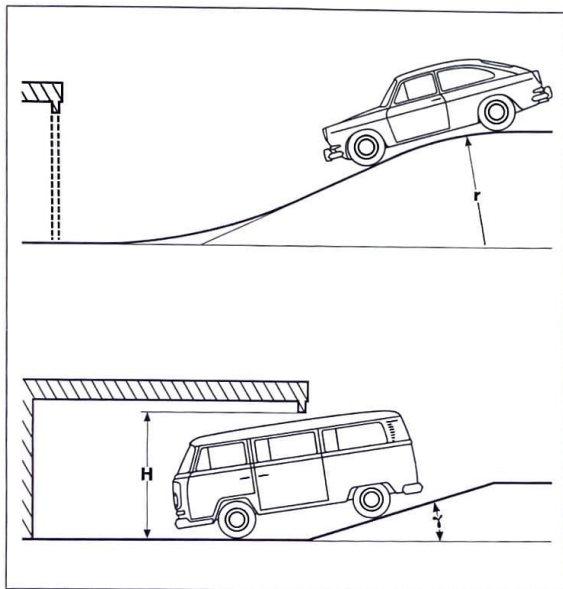

Hinweis:  
Die Höhenabmessung dieser Modelle weicht wesentlich von der aller anderen Volkswagen ab.  
Bitte, beachten Sie dies bei der Festlegung der Einfahrtshöhe.

Note:  
The heights of these models differ considerably from those of all other Volkswagen vehicles.  
Please take this into account when deciding on the height of the entrance.

Indication:  
La hauteur de ces modèles diffère notablement de celle de toutes les autres Volkswagen.  
Veuillez en tenir compte lors de la détermination de la hauteur d'entrée.

Osservazione:  
L'altezza di questi modelli differisce notevolmente da quella di tutte le altre Volkswagen.  
Vi preghiamo di tenerne conto nel calcolo dell'altezza d'entrata.

Aanwijzing:  
De hoogte van deze modellen wijkt aanzienlijk van die van alle andere Volkswagen af.  
Let hier s. v. p. op bij het bepalen van de doornijhoogte.

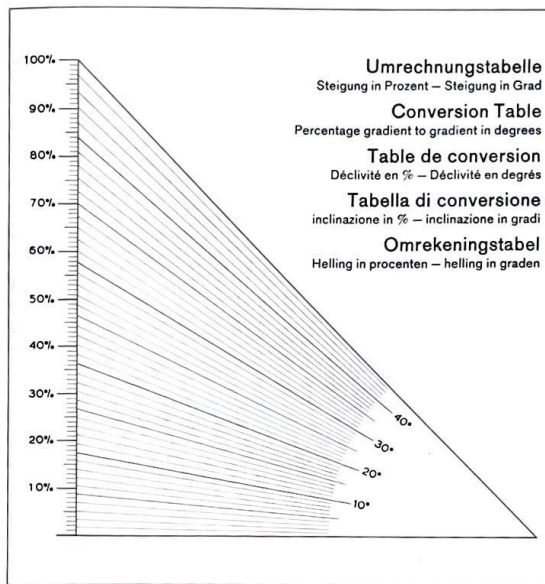

**Umrechnungstabelle**  
Steigung in Prozent – Steigung in Grad  
**Conversion Table**  
Percentage gradient to gradient in degrees  
**Table de conversion**  
Déclivité en % – Déclivité en degrés  
**Tabella di conversione**  
inclinazione in % – inclinazione in gradi  
**Omrekeningstabel**  
Helling in procenten – helling in graden

<sup>1)</sup> ohne Plane und Spriegel  
<sup>2)</sup> mit Plane und Spriegel  
<sup>3)</sup> without tilt and bows  
<sup>4)</sup> with tilt and bows

$\alpha = 15^\circ$ $\gamma = 15^\circ$ $r = m$ (ft.) 5,20 (17.1) $H^* = m$ (ft.) 1,85 (6.1)	$\alpha = 15^\circ$ $\gamma = 15^\circ$ 5,20 (17.1) 1,85 (6.1)	$\alpha = 12^\circ$ $\gamma = 12^\circ$ 5,20 (17.1) 1,65 (5.4)	$\alpha = 12^\circ$ $\gamma = 12^\circ$ 5,20 (17.1) 1,65 (5.4)
$\alpha = 15^\circ$ $\gamma = 14^\circ$ $r = m$ (ft.) 5,20 (17.1) $H^* = m$ (ft.) 1,80 (5.9)	$\alpha = 15^\circ$ $\gamma = 14^\circ$ 5,20 (17.1) 1,80 (5.9)	$\alpha = 13^\circ$ $\gamma = 12^\circ$ 5,20 (17.1) 1,80 (5.9)	$\alpha = 15^\circ$ $\gamma = 14^\circ$ 5,20 (17.1) 1,70 (5.6)
$\alpha = 16^\circ$ $\gamma = 16^\circ$ $r = m$ (ft.) 6,1 (20) $H^* = m$ (ft.) 1,85 (6.1)	$\alpha = 16^\circ$ $\gamma = 16^\circ$ 6,1 (20) 1,85 (6.1)	$\alpha = 17^\circ 30'$ $\gamma = 16^\circ 30'$ 5,03 (16.5) 2,10 (6.9)	$\alpha = 21^\circ$ $\gamma = 15^\circ$ 2,3 (7.5) <sup>1)</sup> 2,55 (8.5) <sup>2)</sup>

<sup>1)</sup> Mindesthöhe - siehe Skizze - minimum height - see drawing - hauteur minima - voir esquisse  
<sup>2)</sup> altezza minima - ved. schizzo - minimum hoogte - zie schets



Kastenwagen  
Kombiwagen  
Großraumkastenwagen  
Feuerlöschfahrzeug (mit Blaulicht)  
Sieben-, Acht- und Neunsitzer

Delivery Van  
Kombi  
High Roof Delivery Van  
Fire Truck (with blue light)  
Station Wagon (Micro Bus)

Camionnette  
Combi  
Camionnette à toit rehaussé  
Fourgon-pompe d'incendie (avec flash bleu)  
Sept, Huit et Neuf Places

Furgone  
Promiscuo  
Furgone con tetto rialzato  
Furgone antincendio (con luce blu)  
Giardinetta Lusso, Giardinetta Speciale

bestelwagen  
combi  
bestelwagen met vergrote laadruimte  
brandweerwagen (met blauw zwaailicht)  
7-, 8- en 9-persoons

● c = mm (in.)	●● H = m (ft.)
1955 (75)	2,30 (7.5)
1950 (76.8)	2,30 (7.5)
2290 (90.2)	2,65 (8.7)
2185 (86)	2,55 (8.4)
1940 (76.4)	2,30 (7.5)

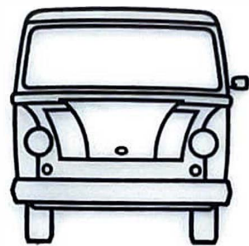
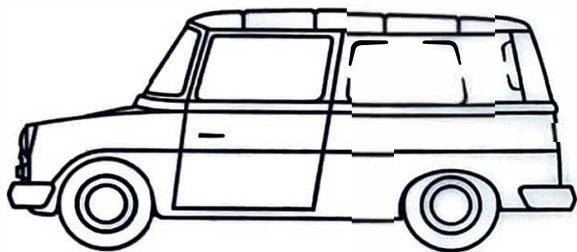

1:100

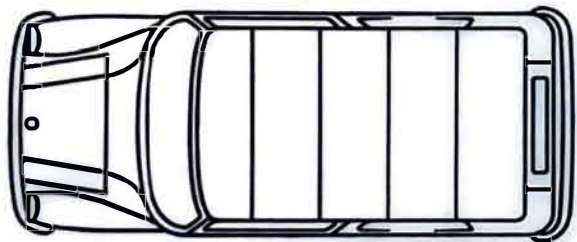
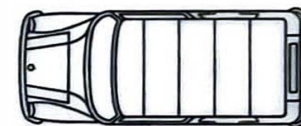
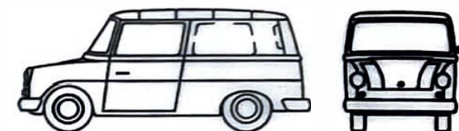

1:50

1:200



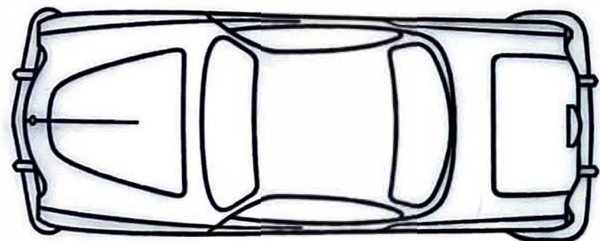
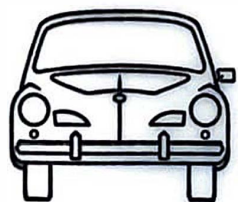
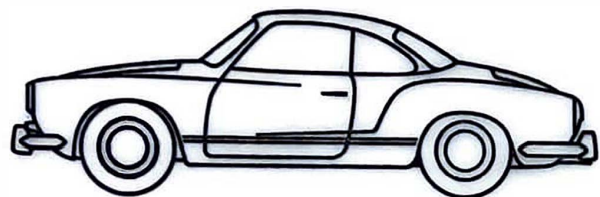

**1:50**

**1:100**

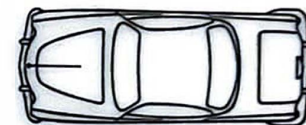

**1:200**

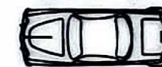
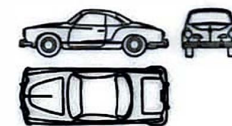



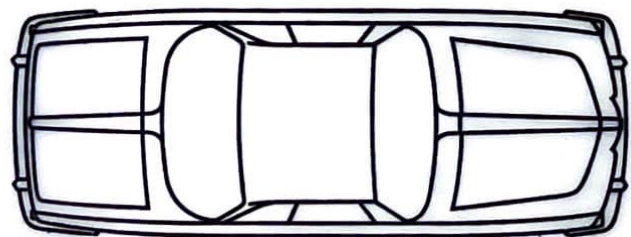
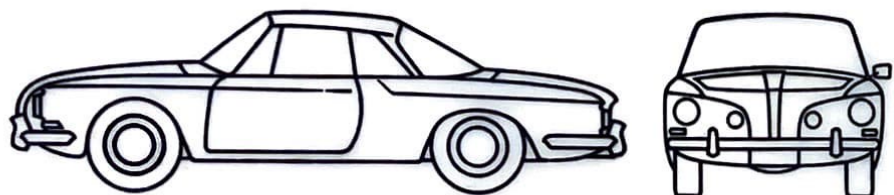

**1:50**

**1:100**

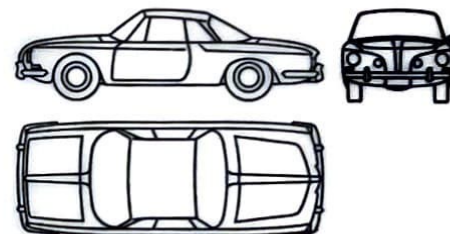

**1:200**



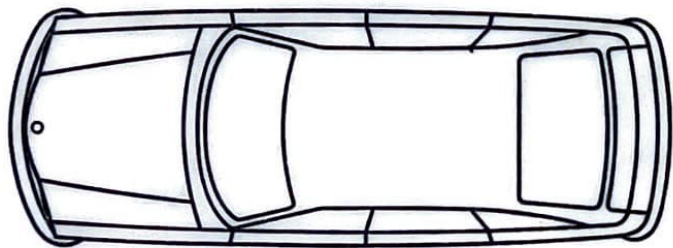
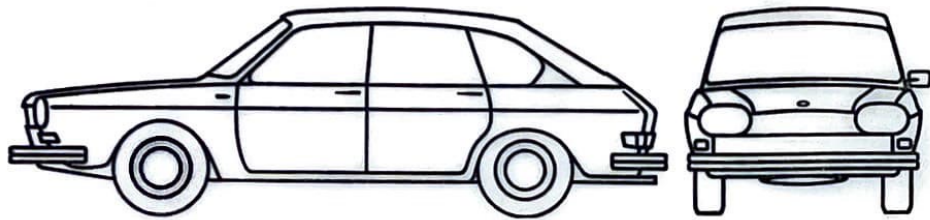

**1:50**

**1:100**

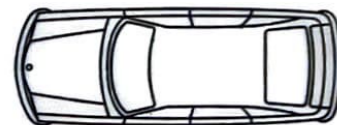
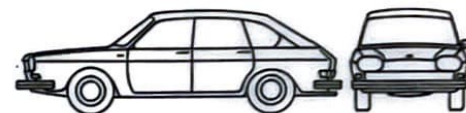

**1:200**



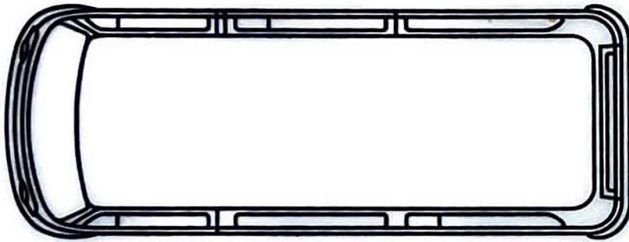
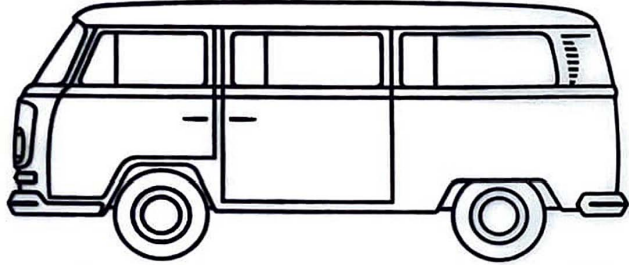

**1:50**

**1:100**

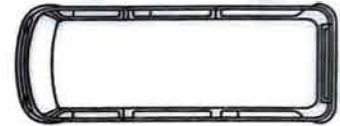
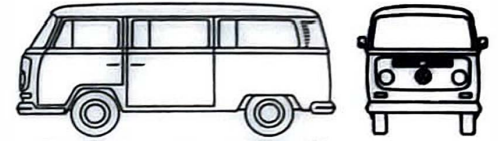

**1:200**





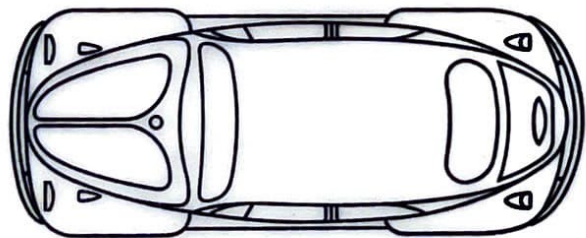
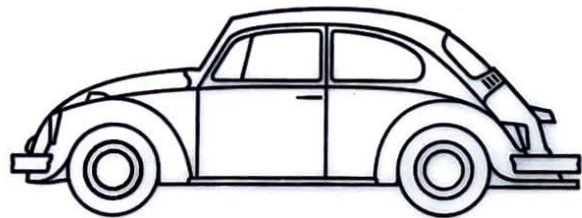

**1:50**

**1:100**

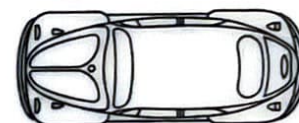

**1:200**



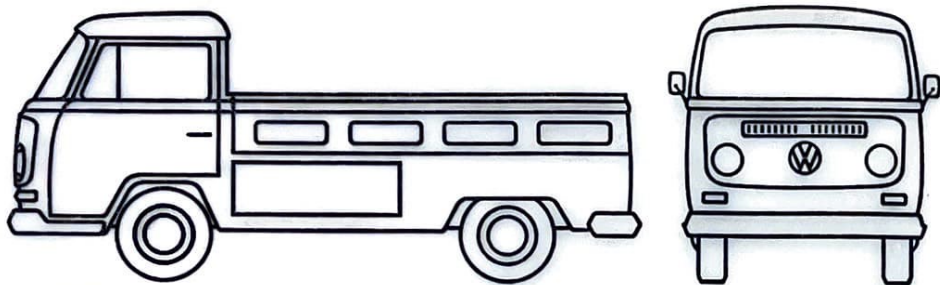

1:50

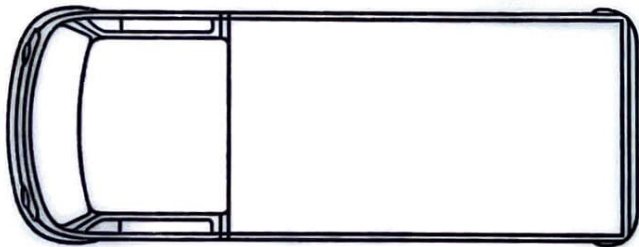

1:100

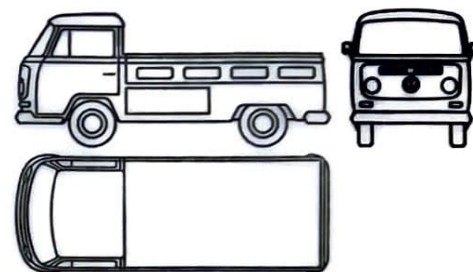

1:200

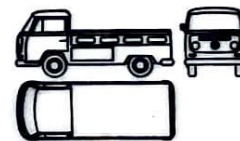

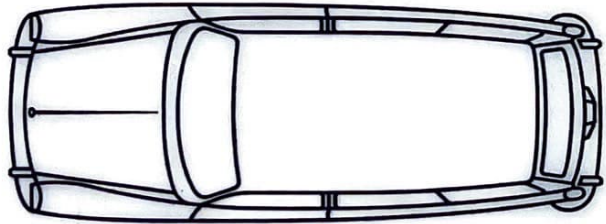
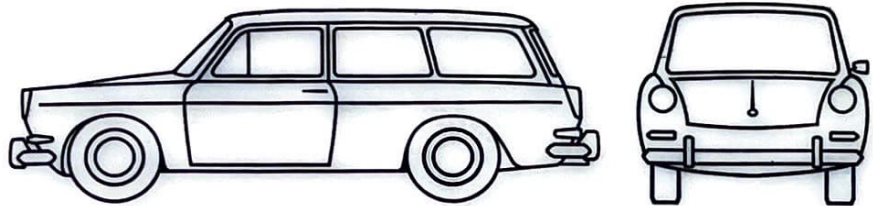

**1:50**

**1:100**

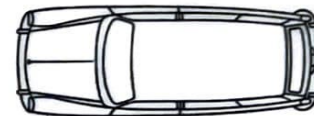

**1:200**





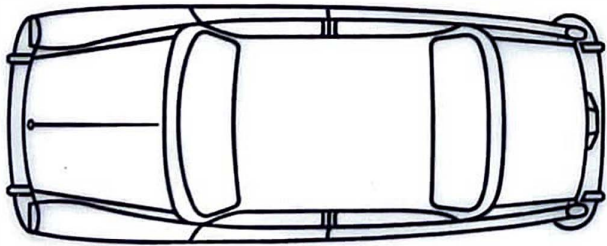
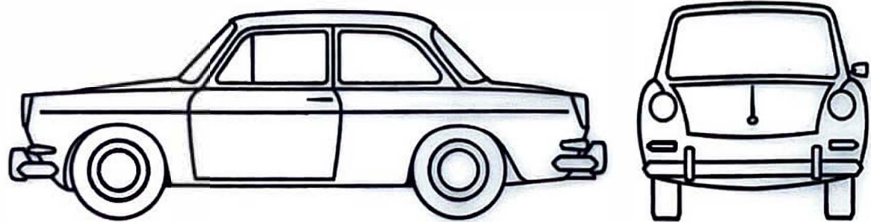

**1:50**

**1:100**

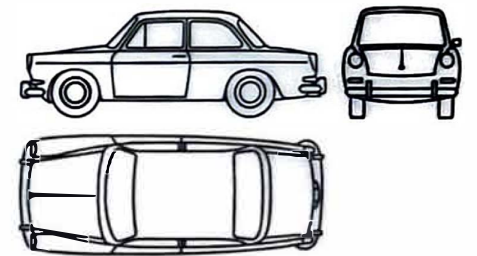

**1:200**

